

Model: BF-600-V-Bank**FEATURES**

Construction facilitates the insertion of double row filters that extend from the left to the right across the canopy length to ensure an even flow of air over the entire length. Seams are continuous throughout the length and width (there are no upstanding or protruding joints). All the joints are welded together. Ground and polished to the original material texture. The use of bolts, nuts and rivets are avoided. All sharp edges and burs are cleaned and polished to ensure safety of cleaning personnel. Internal crevices between canopy joints are filled with a polyurethane or silicone sealer.

FILTERS:

Impingement baffle type filters manufactured of 0.7mm grade 430 st steel. Filters are easily fitted without the use of tools. They slide into the position provided by the filter housing frame. When fitted in position the filter also acts as a fire barrier. The filters are self draining and do not block with grease when used for prolonged periods without cleaning intervals.

APPLICATION:

Extracts steam produced by present day catering equipment. Especially used over island type cooking equipment.

WORKING PRINCIPLES AND SCHEMATIC DRAWING

**Canopy Length
mm**

**Air Volume
m3**

1000	0.80
1200	0.96
1400	1.12
1600	1.28
1800	1.44
2000	1.60
2200	1.76
2400	1.92
2600	2.08
2800	2.24
3000	2.40
3200	2.56
3400	2.72
3600	2.88
3800	3.04
4000	3.20

1. VORTEX BAFFLE TYPE FILTER

First stage baffle impingement filter system.

2. FIRE DAMPER

fusible link activated 140°C

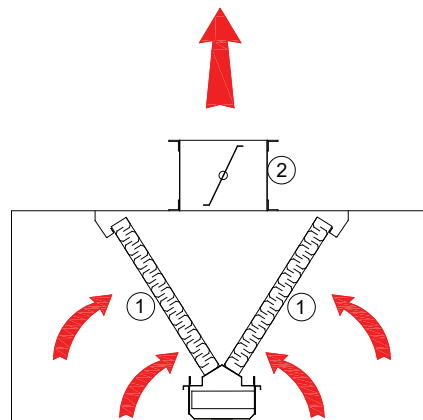

Canopy size

Fire Damper size

1000 - 1300	400 x 300
1400 - 1800	600 x 300
1900 - 2200	700 x 300
2300 - 2500	800 x 300
2600 - 2800	900 x 300
2900 - 3400	1100 x 300
3500 - 3800	1200 x 300
4100 - 4400	1300 x 300

