



900 Electric Flattop

Model: E-FT/900
Dimensions: 900 x 800 x 900

Features

Top made from 1.6mm Grade 430 st/steel
Body manufactured from 0.9mm Grade 430 st/steel
Splash guards manufactured from 2.0mm Grade 430 st/steel
6 x 1.5kw incoloy elements
Elements thermostatically controlled between 0-300 C

Technical Drawing

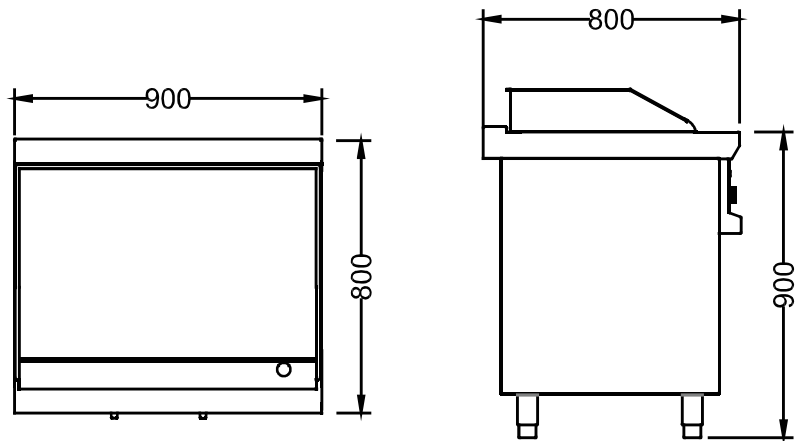

Optional Extras

- Body can be manufactured from 304 st/steel
- Front door to suit body
- Marinade holder

Specifications

Dimensions: 900 x 800 x 900
No of elements: 6 off
Electrical load: 9 kw, 400v, 3 phase neutral and earth
Electrical connection: 2 meter (5 core) cable with fly lead