



### 600 Electric Flattop

**Model:** E-FT/600  
**Dimensions:** 600 x 800 x 900

#### Features

Top made from 1.6mm Grade 430 st/steel  
Body manufactured from 0.9mm Grade 430 st/steel  
Splash guards manufactured from 2.0mm Grade 430 st/steel  
6 x 1.5kw incoloy elements  
Elements thermostatically controlled between 0-300 C

#### Technical Drawing

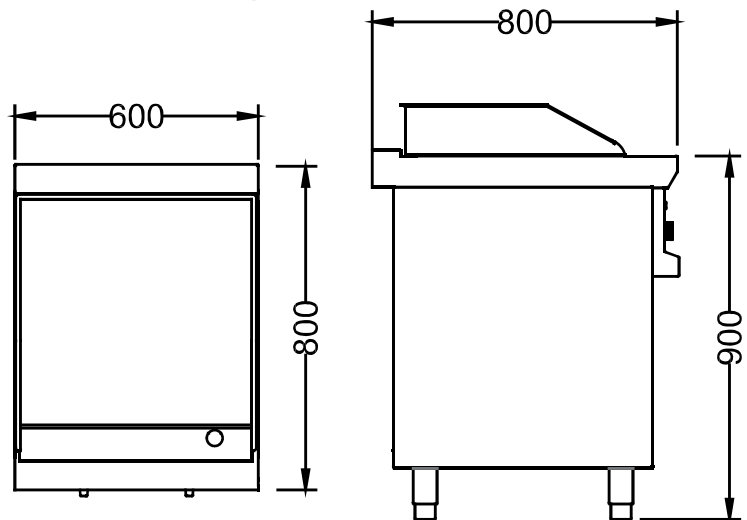

#### Optional Extras

- Body can be manufactured from 304 st/steel
- Front door to suit body
- Marinade holder

#### Specifications

**Dimensions:** 600 x 800 x 900  
**No of elements:** 6 off  
**Electrical load:** 9 kw, 400v, 3 phase neutral and earth  
**Electrical connection:** 2 meter (5 core) cable with fly lead