

TROLLIES

Mobile Cuttlery Trolley

Features

1. **Shelves** - Manufactured from various grades of st/steel (See options).
2. **Frame** - Manufactured from 1.5mm grade 304 st/steel.
3. **Casters** - 2 x braked casters are fitted and 2 x unbraked casters.



Drawings

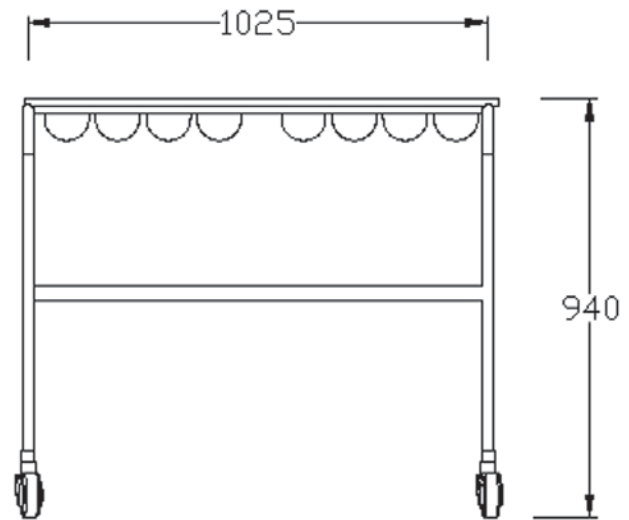
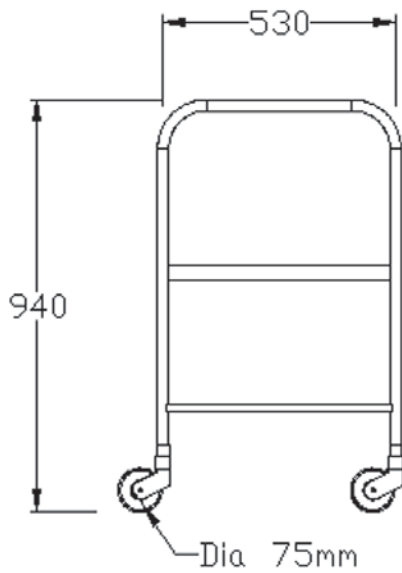

Specifications

Dimensions: 1025(W) x 530(D) x 940(H)
Casters: 75mm diameter

Optional Extras

Shelves can be manufactured from:
0.9mm 430 st/steel
1.2mm 430 st/steel
0.9mm 304 st/steel
1.2mm 304 st/steel